

# IMPORTANT SAFETY NOTICE -- ACTION REQUIRED

## 1/1/2017

**For POOL LIFT Models IGAT-180, -135, -90 (not HD or AD models)**

We recently had reports of corrosion resulting in breakage of an out-of-warranty structural element--the inner telescoping component near where it is welded to the cylinder. Without proper maintenance, corrosion formed over many years on the inside and outside of the inner telescope. The corrosion weakened the stainless steel, cracks developed, and the piece failed slowly enough so that no one was hurt. Highly chlorinated and true saltwater pools will have more corrosion on stainless steel surfaces and require regular inspection and maintenance. Based upon reports, heavily used lifts in indoor pools with high chemical concentrations in the air are most at risk. These reports currently **represent 0.04% of the lifts in service, but as the possibility of injury does exist,**

**It is imperative that you examine your lift immediately.**

Remove footrest and seat assembly to lessen weight for handling. With P-Frame in lowered position, remove cylinder from socket/water and lay on deck.

Remove bolt holding together the inner and outer telescoping parts of the mounting arm. Slide outer arm off.

Inspect inside and outside both pieces for corrosion, rust, pits, cracks, and thinning of the metal. A stainless steel wire brush will help remove any rust. Use a rust remover and thoroughly clean any residue and rinse well. Inspect again.

If there is any doubt, remove the lift from service. Send photos of affected parts to [Safety@AquaticAccess.com](mailto:Safety@AquaticAccess.com).

If the pieces are sound, continue service, but inspect periodically for corrosion on these parts, and clean and polish as needed.

Use this opportunity to inspect and service your entire lift. Check the metal condition, welds, valve, hoses, all plastic parts, missing or loose bolts, etc. Order parts if needed.

**Thank you for your immediate attention and cooperation in this important effort.**

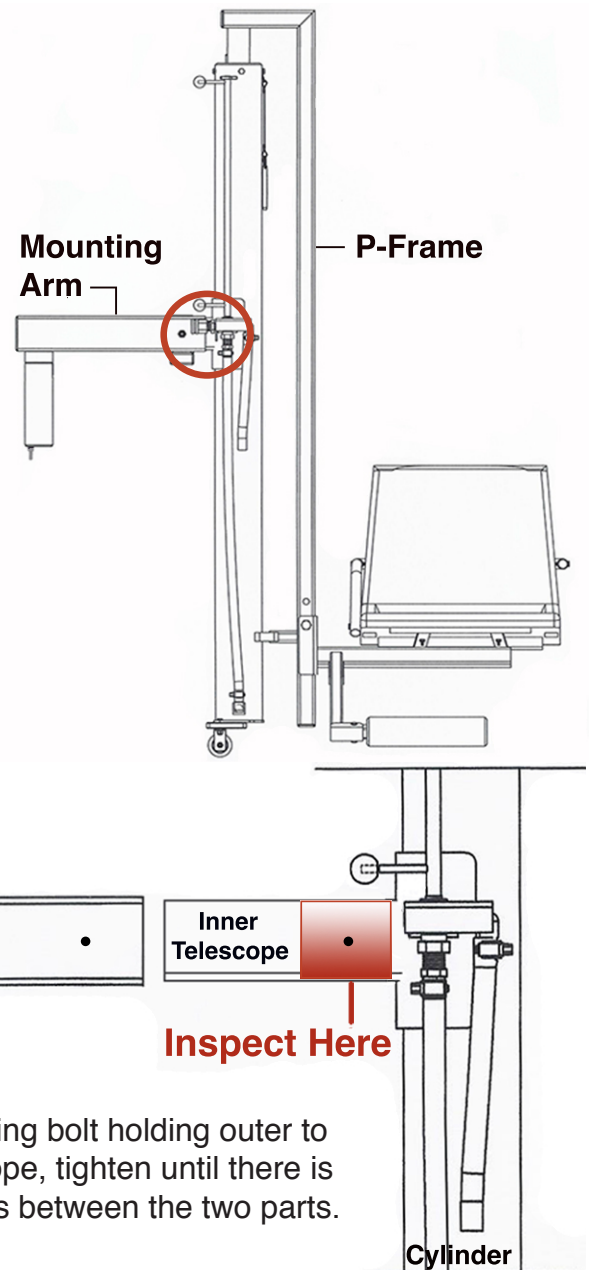

Note:  
When installing bolt holding outer to inner telescope, tighten until there is no looseness between the two parts.